

The Pluto-New Horizons RTG and Power System Early Mission Performance

Geffrey K. Ottman* and Christopher B. Hersman†

Johns Hopkins University Applied Physics Laboratory, 11100 Johns Hopkins Road, Laurel, Maryland, 20723, USA

On January 19, 2006, the Pluto-New Horizons spacecraft was launched from Cape Canaveral Air Force Station (CCAFS) with a radioisotope thermoelectric generator (RTG) as the power source and a 30V power regulation and distribution system designed and built by the Johns Hopkins University Applied Physics Laboratory. Pluto-New Horizons is the flagship spacecraft of NASA's New Frontiers program of medium-class interplanetary missions and targets the first reconnaissance of Pluto and its moon, Charon, and the Kuiper Belt. Arrival at Pluto is scheduled for July, 2015 at which time the spacecraft will have traveled 3 billion miles and be almost 32 AU from the sun. Due to the extended mission duration and extreme distance from the sun, a RTG was chosen as the spacecraft's power source. RTG missions place complexity on the spacecraft power system design due to their unique power characteristics and limited opportunities for test prior to pre-launch field operations. The RTG integration and test with the spacecraft results are presented along with the spacecraft power system performance during launch and in the early mission phase. These in-flight operational results demonstrate a fully functioning power system that will supply the spacecraft with safe and reliable power during the exploration of the farthest reaches of the solar system.

I. Mission Description

THE Pluto-New Horizons spacecraft is currently en route to Pluto and its moons to perform scientific reconnaissance of the last unexplored planet in the solar system. In 2002, the National Research Council's Planetary Decadal Survey ranked the exploration of the Pluto and the Kuiper Belt as the "Highest Priority" for solar system exploration. Pluto and Charon as well as the Kuiper Belt Objects (KBOs) are believed to be in the third class of planets called "ice dwarfs". These objects are believed to contain the embryonic building blocks of the universe and hold great promise in advancing our understanding of the formation of the solar system.

The Pluto-New Horizons spacecraft was launched on an ATLAS V 551 evolved expendable launch vehicle (EELV) on January 19, 2006 at 14:00:00 EST. The Centaur second stage and a Star 48B solid rocket motor third stage completed the initial phase of the spacecraft's journey. The spacecraft's trajectory, shown in Fig. 1, takes it by the planet Jupiter thirteen months after launch¹. By passing close to the planet, the spacecraft will receive a Jupiter gravity assist (JGA) to increase its velocity. During this pass, the spacecraft and science instruments will undergo a complete rehearsal of the Pluto encounter to fully demonstrate their capabilities. After the Jupiter encounter, the spacecraft will be put in a hibernation state to

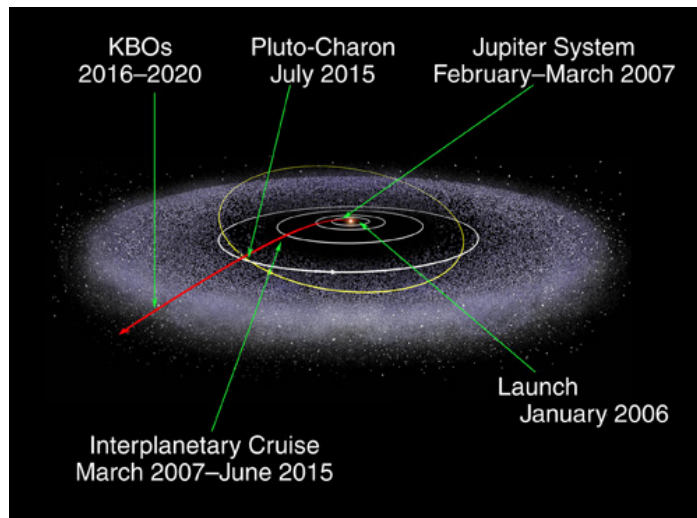

Figure 1. Pluto-New Horizons mission trajectory²

* Associate Staff Engineer, Space Department, IEEE Member.

† Principle Professional Staff Engineer, Space Department, AIAA and IEEE Member.

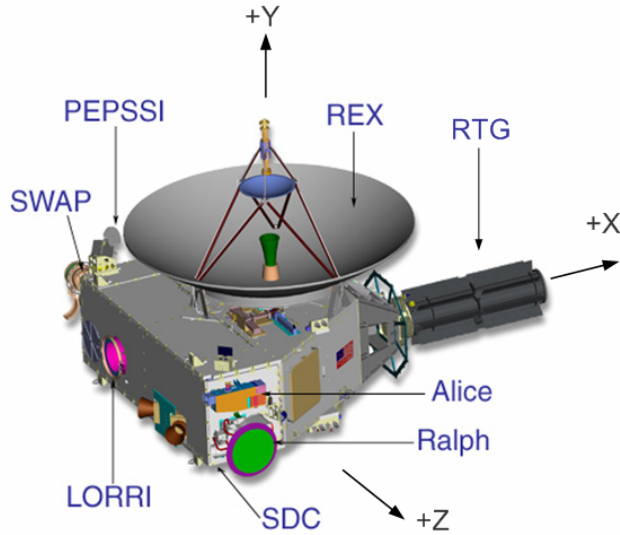

Figure 2. Pluto-New Horizons Spacecraft and Instruments²

characterization of Pluto's atmosphere and its escape rate³. The 478 kg spacecraft and its suite of 7 instruments are shown in Fig. 2. The telescopic camera, LORRI (Long Range Reconnaissance Imager), will be used from longer distances to map Pluto's surface and provide high resolution geological data. Closer in, the Ralph instrument, a visible and infrared imager and spectrometer, will make color, composition and thermal maps. The Alice instrument is an ultraviolet imaging spectrometer used to analyze the composition and structure of Pluto and Charon's atmospheres. The Radio Science Experiment (REX) will measure planetary atmospheric composition and temperature. The SWAP (Solar Wind Around Pluto) instrument is a plasma spectrometer that will measure the atmospheric escape rate of Pluto and the planet's interaction with the solar wind. The PEPSSI instrument is an energetic particle spectrometer designed to measure the composition and density of plasma (ions) escaping Pluto's atmosphere. The final instrument is Student Dust Counter (SDC) which will measure the space dust impacting the spacecraft during its voyage across the solar system.

II. Power System Overview

The Pluto-New Horizons spacecraft bus was designed and built by the Johns Hopkins University Applied Physics Laboratory (APL). It is a fault tolerant design with redundant components for all major bus electronics. A block diagram of the spacecraft and its subsystems is shown in Fig. 3. The spacecraft electrical power source is a radioisotope thermoelectric generator (RTG) with a design baseline of 10.9 kilograms of plutonium-238 dioxide, housed in 18 general purpose heat source (GPHS) modules³, Fig. 4. The nuclear fuel provides a source thermal energy that is converted to electrical power using silicon-germanium thermoelectric devices (solid state uncouples). The efficiency for a GPHS style RTG is 6.4%⁵ and has an annual power loss of approximately 0.8% due to the radioactive decay of the isotope fuel⁶. An independent conceptual design of the Pluto Kuiper Express mission baselined a GPHS RTG with a power output of 290 W (electric) at the beginning of the mission with 231 W (electric) at Pluto⁷. The spacecraft system design complements the power delivery characteristics of an RTG by power regulation at a selected voltage and through thermal control at the RTG interfaces.

The Pluto-New Horizons RTG, denoted as F-8, was provided by the U.S. Department of Energy⁸. The iridium cladding used to encapsulate the plutonium was fabricated by the Oak Ridge National Laboratory⁸. Plutonium purification and processing took place at Los Alamos National Laboratory⁸. Originally, the RTG was to be fueled with newly processed plutonium purchased from Russia^{11,12,13}. A facility shutdown at Los Alamos in the summer of 2004 caused significant delays to their Pluto fuel processing efforts¹⁴. As a result, the RTG was fueled with only 9.75 kg of total plutonium which was a mixture of fuel retrieved from RTG F-5 from the Galileo, Ulysses and CASSINI missions^{9,10} and newly processed fuel sources. This change reduced the RTG power by approximately 15% from the original baseline design estimate. The thermal to electric converter was fabricated by Lockheed Martin Space Power. GPHS assembly, RTG fueling and F-8 acceptance testing were completed at the Idaho National Laboratory⁸.

reduce mission cost with annual checkouts of the subsystems and instruments to verify their health and functionality.

With the Jupiter gravity assist, the spacecraft will arrive at Pluto on July 14, 2015, 9.5 years after launch. The encounter phase with Pluto will take place over a seven month period in which the spacecraft will fly within 10,000 km of Pluto and 27,000 km of Charon. Due to the limited telecommunications bandwidth at the encounter (earth distance of >32 AU¹), the data from the science phase of the mission will take up to 9 months to be completely returned. Once this initial science phase is completed and pending NASA approval, the mission will target one or more KBOs for scientific observation.

The science objectives of the Pluto-New Horizons mission are to measure the physical and chemical properties of Pluto and Charon with emphasis on the characterization of the global geology, surface composition mapping, and the

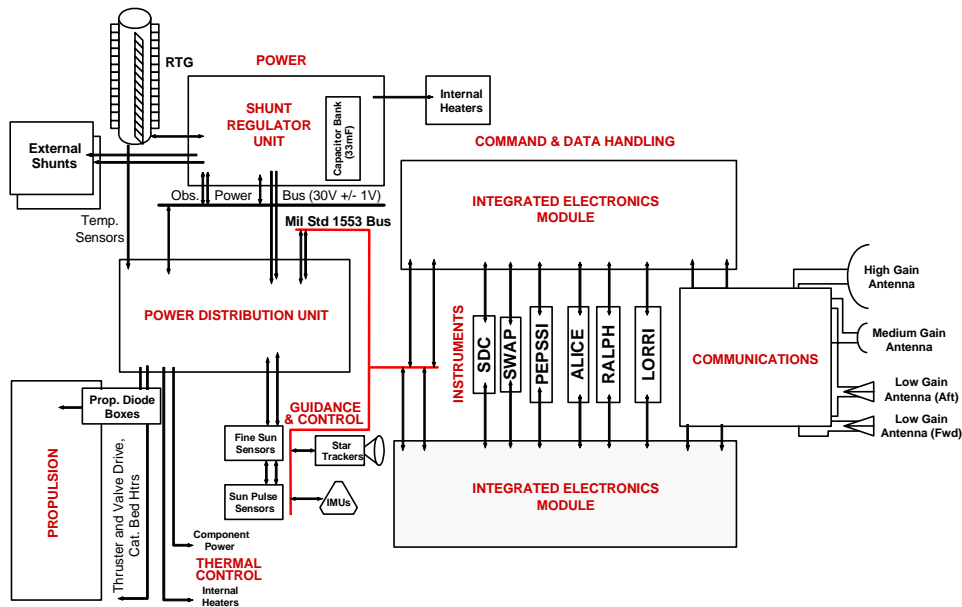

Figure 3. Pluto-New Horizons Spacecraft Block Diagram

The RTG represents a single point failure for the Pluto-New Horizons mission. As a result of its criticality to the spacecraft, several risk mitigation strategies were employed. The power system isolated the RTG case (chassis) from the power and return pins. This protected the mission from a RTG internal short between the chassis and power pins. The RTG has only a single circular connector with redundant power pins for the power connections. On the spacecraft side, each pin from this connector had two harness wires attached to it. This design resulted in a power “Y” cable that produced two connectors for mating to the power system for additional redundancy. The impedance of this cable assembly was estimated at 45 milli-Ohms. The “Y” cable, along with the observatory power bus, was double insulated to prevent shorts to the spacecraft structure.

Other features of the RTG include four resistance temperature devices (RTD) for temperature monitoring and a pressure relief device (PRD). The RTDs are located at 90 degree intervals approximately one-eighth of the RTG length from the spacecraft mounting end. Two RTDs were routed to each side of the spacecraft’s telemetry system providing limited redundancy of the RTG temperature sensors. The PRD is activated at launch and vents the internal gas of the RTG allowing it to operate in the vacuum of space.

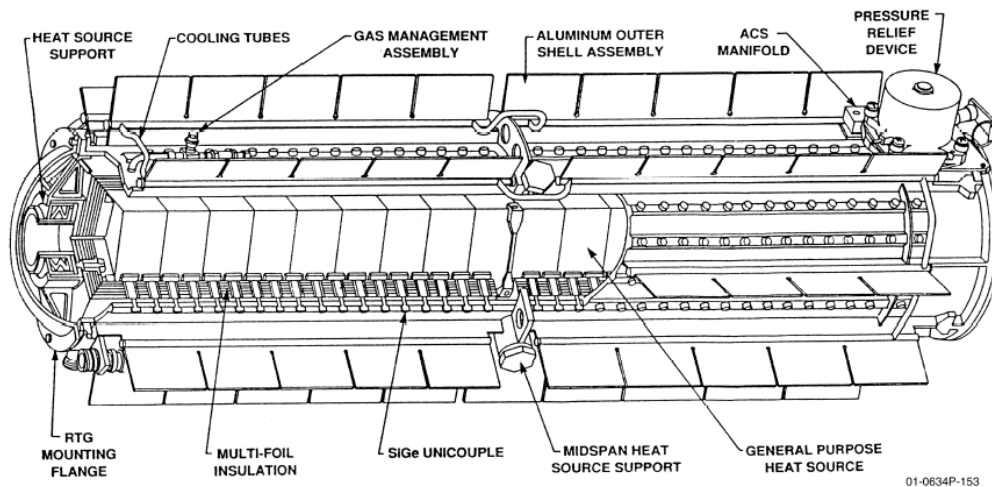

Figure 4. General Purpose Heat Source RTG⁴

The spacecraft electrical power system is made up of a triple-voted shunt regulator unit (SRU) and a fully redundant power distribution unit (PDU). The power system design was constrained by the limited power nature of an RTG mission and the long lifetime for the mission; details of the design can be found in Ref. 15. The RTG is tied directly to the spacecraft power bus with the SRU as its electrical power interface. The SRU contains three independent linear controllers that are voted to regulate the power bus to 30.25V. This voltage balances the need for an adequate power distribution voltage to spacecraft loads with the desire to operate the RTG near its peak power point of ~30V. The SRU regulates the electrical bus by dissipating excessive RTG power in sixteen linear sequential shunts. Each shunt is sized to dissipate 19.5W. The external shunts are resistive elements mounted on two panels outside of the spacecraft's thermal boundary that radiate unnecessary power to space. The first three shunts can be steered to internal heaters for use late in the mission. The SRU also houses a 33.6 mF capacitor bank that provides for short duration current surges at load turn or fault conditions. The twenty-four capacitors, as well as the controllers and shunt MOSFET drivers, are all individually fused.

The PDU contains many features to protect against mission ending faults. The RTG is power limited and capable of stable operation outside of a normal spacecraft bus electrical range, 22-36V, so PDU features include a dual level fast low-voltage load shed, redundant load circuit breakers with linear current limiting, and critical load switching. All loads are also fused as a final layer of protection to the spacecraft's electrical bus. To meet redundancy requirements, all loads can be commanded through two independent communications paths, via either the redundant MIL-STD-1553B bus or through the redundant serial UART links with the spacecraft critical command decoder located within the integrated electronic module. The Pluto-New Horizons PDU has power services for 98 switched loads, 60 thruster/latch valve drivers, 164 pulsed outputs and 16 opto-isolated contact closures.

III. Power System Electrical Ground Support Equipment (EGSE)

The spacecraft power system development also required several key pieces of EGSE. To facilitate testing of the power system prior to integration of the fueled RTG, an RTG electrical simulator was designed. It included internal source impedance approximately equal to that of the RTG and protection features such as current limiting fusing and an over voltage clamp. These features allowed for safe operation of the power system and spacecraft during potential failures of the SRU, shunt panels, or the ground power supply. During early spacecraft integration, a shunt panel simulator was used in conjunction with the RTG simulator for complete power system functional testing. .

A shorting box and shorting plug were designed for use during the transfer of the RTG and its mating with the spacecraft. The shorting box contained linearly controlled solid state transistors to "ramp" the RTG to a shorted or opened condition at its power pins. This box was used to short the unloaded RTG so the mating to the spacecraft could be performed without concerns of excessive SRU capacitor inrush current or potential connector arcing. The box was designed to withstand an RTG open-circuit voltage above 60V and a RTG shorted current of over 20A. The shorting plug directly connected the RTG power and return pins and was used during transport of the RTG.

IV. Integration and Test

The SRU and PDU were designed, tested, and qualified in tandem using the RTG and shunt panel simulators. Key power system tests involved the measurement of SRU response during load fault simulations resulting in tripped PDU circuit breakers; bus overload condition which forced an under voltage reset and recovery of the power system; and SRU AC loop response gain-phase measurements during PDU operation.

To allow for spacecraft and RTG testing, early field operations included a hot fit check of the two components. During this test, RTG ground operations power was reduced due to the argon gas fill, which protects against the leakage of air into the RTG inner void. This test also served as a mechanical fit check and as a rehearsal for the actual flight mating of the RTG. The 24-hour testing period successfully demonstrated the suitability of the EGSE, the power system and the spacecraft loads with the RTG power source. During the spacecraft harness attachment to the RTG for this test, the RTG measured 38.4 V open-circuit and 17.1 A short-circuit. Within 6 hours of mating with the spacecraft, the RTG power stabilized at 101.2 W at a temperature of 164°C. RTG case isolation was calculated as 1.05M Ohms to the power pins and 237K Ohms to the return pins.

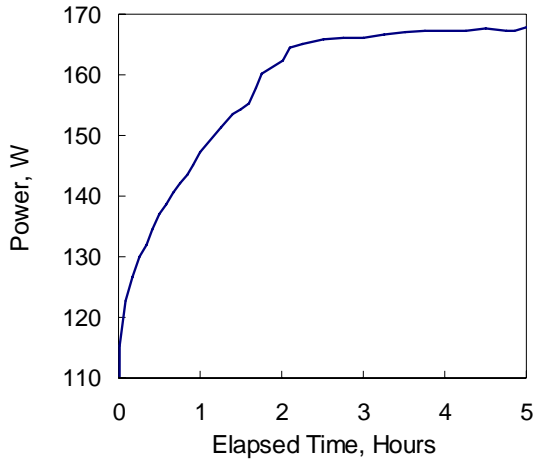

Figure 5. Spacecraft power-up during RTG flight mate

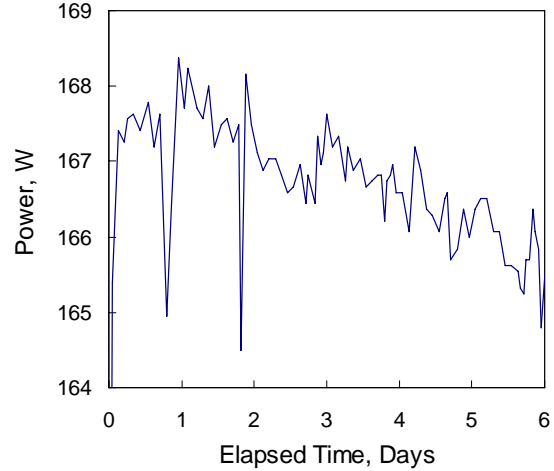

Figure 6. RTG power output during pre-launch interval

V. Pre-Launch Performance

The flight mate of the RTG to the spacecraft occurred at the launch vehicle vertical integration facility (VIF) four days before the opening of the launch window. Prior to the transfer of the RTG, the argon gas fill was replaced with xenon to achieve a higher temperature differential across the unicouples thus increasing the power output. During the spacecraft harness attachment, the RTG measured 41.1 V open-circuit and 18.5 A short-circuit. RTG power stabilization occurred 4 hours after the mating with the RTG supplying 167.7 W at a temperature of 141°C. A telemetry plot of the spacecraft power up with the RTG is shown in Fig. 5. The RTG power supplied to the spacecraft is calculated by multiplying the current measured out of the RTG by the regulated bus voltage value, 30.25 V. The bit resolution of the RTG telemetry is 2.45 mA per bit or 74.1 mW per bit. Actual power produced by the RTG is higher than the values shown due to the resistive losses of the spacecraft's electrical power harness and the operation of the RTG slightly off of its peak power voltage.

A functional test of the power system was conducted after RTG installation. This test demonstrated a fully functional power system with no issues resulting from the flight RTG mate. During the interval preceding launch, the spacecraft telemetry was monitored for RTG output power and temperature and the spacecraft electrical bus regulation voltage. The RTG power output during this interval is shown in Fig. 6. The xenon filled RTG power decayed due to helium contamination of the xenon causing the coefficient of thermal conductivity for the gas fill to increase which accounted for ~0.3 watts daily power loss. Prior RTG missions experienced a similar power loss due to dopant precipitation effects¹⁶. Daily dips in power were attributed to slight changes in the ambient thermal conditions inside the launch vehicle fairing. The VIF was subject to heating as the sun rose on the Florida coast causing the air conditioning system to cycle on to maintain the temperature inside the fairing.

VI. Launch Performance

The launch window for the Pluto-New Horizons mission opened on January 17, 2006 at 13:24 EST. High winds were prevalent during the two-hour window and precluded a safe launch. The next day was also scrubbed due to a weather induced power loss at the mission operation center located at APL in Laurel, Maryland. On January 19, 2006 the countdown resumed at 13:08 EST but was delayed multiple times due to low cloud cover at the launch site. At 14:00:00 EST, the spacecraft



Figure 7. Liftoff of the ATLAS V Launch Vehicle and the Pluto-New Horizons Spacecraft (KSC-06PD-0101)²

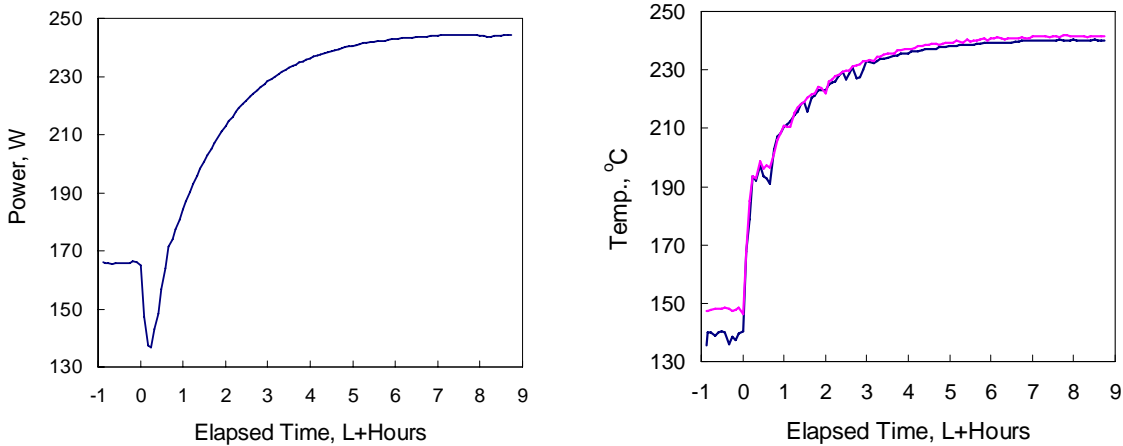

Figure 8. RTG power output and temperature telemetry during launch

lifted off amid a break in the clouds, Fig. 7. At launch, the spacecraft entered a 45 minute period of no contact. This interval included the RTG ramp up to full power and puncturing of the PRD. The recorded data for the RTG power and temperature sensors #1 and #2 from this period are shown in Fig. 8. The initial power dip to 137 W (almost 20% loss) was due to the removal of the air conditioning and the resulting heating inside the launch vehicle fairing¹⁶. Upon separation of the launch vehicle fairing at launch plus 3 minutes (L+3 minutes), the RTG power begins to climb on a characteristic exponential rise, settling out at 245.7 watts of electrical power measured at the spacecraft power bus at L+8 hours. The temperature telemetry points follow a similar curve, stabilizing at 242°C with a slight dip observed on both sensors at L+25 minutes. At the final power level, the harness losses were estimated to be less than 3 W. First contact power system telemetry also showed a properly functioning power system with no anomalies encountered during the launch period.

VII. Early Mission Performance

Since the launch of the Pluto-New Horizons spacecraft on January 19, 2006, the RTG and spacecraft power system have continued to function as designed. RTG power and temperature telemetry through mission day 25 are shown in Fig. 9 with transient conditions noted on the plots. The temperature plot uses the primary RTD sensors, #1 (blue) and #2 (magenta), located at $\sim 110^\circ$ and $\sim 20^\circ$ from the +Y axis respectively. Event 1 is the spacecraft spin down from 19.2 to 5 RPM on L+3 days. The RTG power dipped 0.65 W, but fully recovered subsequently. The RTG temperature did not show a corresponding transient response. Event 2 is a spacecraft precession prior to the first spacecraft trajectory correction maneuver (TCM) on L+8 days. The spacecraft sun angle from the y-axis

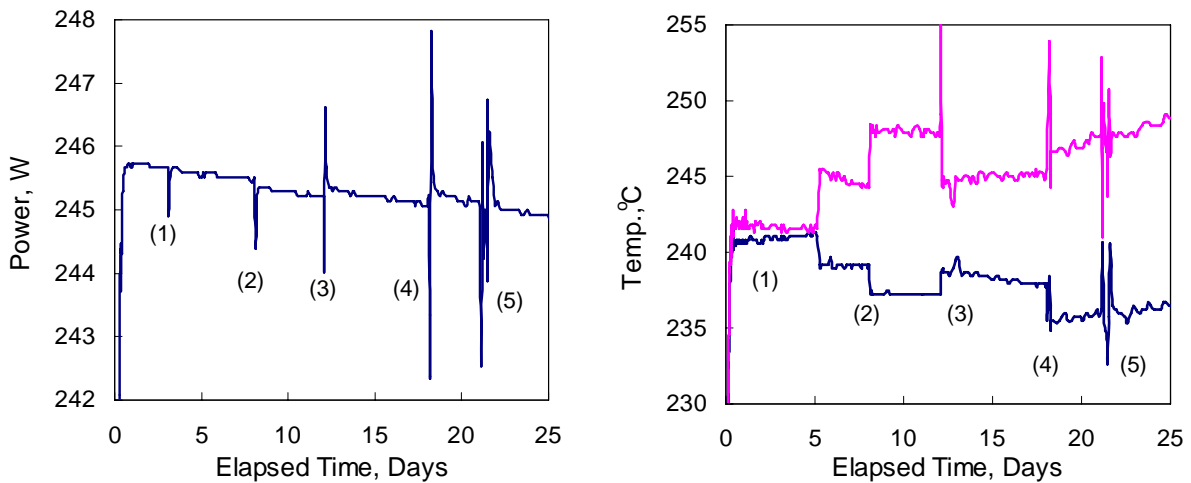

Figure 9. Early mission RTG power output and temperature telemetry through L+25 days

changed from 71° to 30° (the plus y-axis is perpendicular to the RTG in the antenna mast direction). This was a 1.1 W power transient with a steady state loss of 0.1 W. Upon completion of the maneuver, the temperature difference across the RTG is 11°C due to the unequal solar heating of the RTG. In this orientation the “top” of the RTG, the +Y axis side, receives more sun exposure than the “bottom” of the RTG, the -Y axis side, which is predominately shaded throughout the spacecraft’s spin axis. Interestingly, an unlabeled precession on L+5 days changed the sun angle from 97° to 71° with a prominent temperature change (6°C excursion) but no corresponding power transient. Event 3 is an acquisition precession on L+12 days that has both a negative and positive power transient. The steady state gain of RTG power is 0.15 W and the temperature difference across it reduced to 5.5°C . Event 4 is a check out of the spacecraft 3-axis control mode on L+18 days. Event 5 is the calibration of the primary and redundant IMUs on days L+21 and 22. During these periods, the RTG sun angle was constantly changing, producing a complex pattern of power and temperature transients. The Transit spacecraft, a previous APL mission with a SNAP RTG power source, showed a similar relationship between RTG power output and solar incidence during an example orbit¹⁷. The LES spacecraft data showed a power variation due to solar flux affecting the outer case temperature of the MHW-RTG¹⁶. Previous data from the Ulysses mission reported in Ref. 9 discuss a more pronounced pattern of solar heating due to sun-probe distance affecting the RTG output power. A power system functional test was successfully completed on L+14 days to verify the proper operation of the redundant SRU and PDU functions and the cross strapped interfaces to these components.

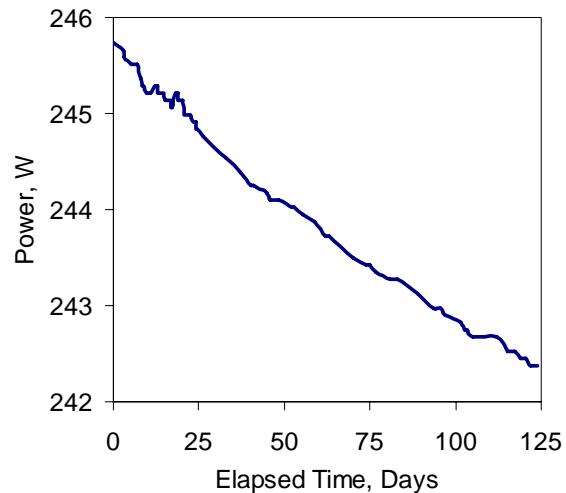

Figure 10. Pluto-New Horizons power system early mission performance through L+125 days

Fig. 10. shows the mission to date performance of the RTG power delivered to the spacecraft. Through the first 125 days of the mission, the power has dropped approximately 1.4% to 242.4 W. This is a 26.4 mW per day reduction of RTG power which is consistent with the performance other GPHS-RTGs documented in Ref. 6.

VIII. Summary

The design of a deep space exploration mission requires a nuclear power source and a spacecraft power system that can accommodate it. Through the efforts of the Southwest Research Laboratory, the Applied Physics Laboratory, and the Department Of Energy and many other contributing organizations, the Pluto-New Horizons spacecraft was successfully built, tested and launched. The spacecraft is now on a 9.5 year transit to its primary goal of Pluto. The Pluto-New Horizons spacecraft and RTG F-8 have performed flawlessly during launch and in the early mission phases. Both systems were designed for the long lifetime of this mission and are poised to support the Pluto-Charon encounter in the summer of 2015 and the subsequent science reconnaissance of multiple KBO(s).

IX. Acknowledgements

The Pluto-New Horizons mission is supported by the NASA New Frontiers program under contract to Southwest Research Institute (SwRI). The efforts of Dr. Alan Stern, the Principal Investigator, were instrumental in achieving a mission to explore Pluto and the design of a cohesive instrument suite and spacecraft. Timothy Hoye and Wayne Tobery of Lockheed Martin Space Power provided invaluable review of the RTG performance data, both pre-launch and in flight. Wade Radford of APL (retired) provided oversight of the spacecraft-RTG effort and historical perspective for the design of a radioisotope power source based mission.

X. References

1. Guo, Y. and Farquhar, R. W., New Horizons Mission Design for the Pluto-Kuiper Belt Mission, *AIAA/AAS Astrodynamics Specialist Conference and Exhibit*, AIAA 2002-4722, pp. 1-10, 2002.
2. New Horizons NASA’s Pluto-Kuiper Belt Mission, <http://pluto.jhuapl.edu/> [cited 8 May 06].
3. National Aeronautics and Space Administration, Final Environmental Impact Statement for the New Horizons Mission, Vol. 1, July 2005, URL: http://www.space.science.nasa.gov/admin/pubs/plutoeis/NH-FEIS_Vol1.pdf [cited 8 May 2006].

4. "Space Radioisotope Power Systems New Horizons Mission (Pluto)", U.S. Department of Energy, dated October 2002, URL: http://www.nuclear.gov/infosheets/MMRTG_Oct2002.pdf [cited 8 May 2006].
5. Pustovalov, A. A., Nuclear Thermoelectric Power Units in Russia, USA and the European Space Agency Research Programs, *Sixteenth International Conference on Thermoelectrics*, pp. 559-562, 1997.
6. Bennett, G. L. and Skrabek, E. A., Power Performance of U.S. Space Radioisotope Thermoelectric Generators, *Fifteenth International Conference on Thermoelectrics*, pp. 357-372, 1996.
7. Nilsen, E. N., Advanced Radioisotope Power Sources for Future Deep Space Missions, *Space Technology and Applications International Forum-2001*, CP552, Vol. 552, Issue 1, pp. 701-706, 2001.
8. Howze, J. and Ehresman, T., "NASA's New Horizons mission also a new horizon for INL", URL: <http://www.inl.gov/featurestories/2006-01-19.shtml> [cited 8 May 06].
9. Kelly, C. E. and Klee, P. M., CASSINI RTG Acceptance Test Results and RTG Performance on Galileo and Ulysses, *Proceedings of the 32nd Intersociety Energy Conversion Engineering Conference*, Vol. 4, pp. 2211-2216, 1997.
10. Johnson, K. S. and Cockfield, R. D., Power and Propulsion for the Cassini Mission, *American Institute of Physics Space Technology and Applications International Forum-STAIF 2005*, pp. 232-239, 2005.
11. Berger, B., "NASA's Pluto Probe to be Delayed or Make Due With Less Power" {IBID}, Space.Com, URL: http://www.space.com/scienceastronomy/pluto_mission_040806.html [cited 8 May 2006].
12. Berger, B. "Origins of Plutonium Pinch Predate Los Alamos Shutdown", Space.Com, URL: http://www.space.com/spacenews/archive04/plutoniummarch_081704.html [cited 8 May 2006].
13. Berger, B. "New Horizons Set To Launch With Minimum Amount of Plutonium", Space.Com, URL: http://www.space.com/spacenews/businessmonday_041004.html [cited 8 May 2006].
14. Berger, B. "Nuclear Lab Shutdown Puts Pluto Mission In Jeopardy", Space.Com, URL: http://www.space.com/scienceastronomy/pluto_losalamos_040803.html [cited 8 May 2006].
15. Carlsson, U., The New Horizons Spacecraft Power System Electronics, *Seventh European Space Power Conference*. SP-589 Vol. 1, pp, 2005
16. Kelly, C. E. and Whitmore, C. W., Performance of the Multi-Hundred Watt Radiototope Thermoelectric Generator (MHW/RTG) Power Source for the LES 8/9 Satellites, *7th Communications Satellite Systems Conference*, pp. 728-735, 1978.
17. Bradshaw, G. B. and Postula, F. D., Beginning of Mission Flight Data on the Transit RTG, *Journal of Spacecraft and Rockets*, Vol. 11, No. 10, pp. 675-676, 1974.